

ST02	A55-A	C	
-------------	--------------	----------	--

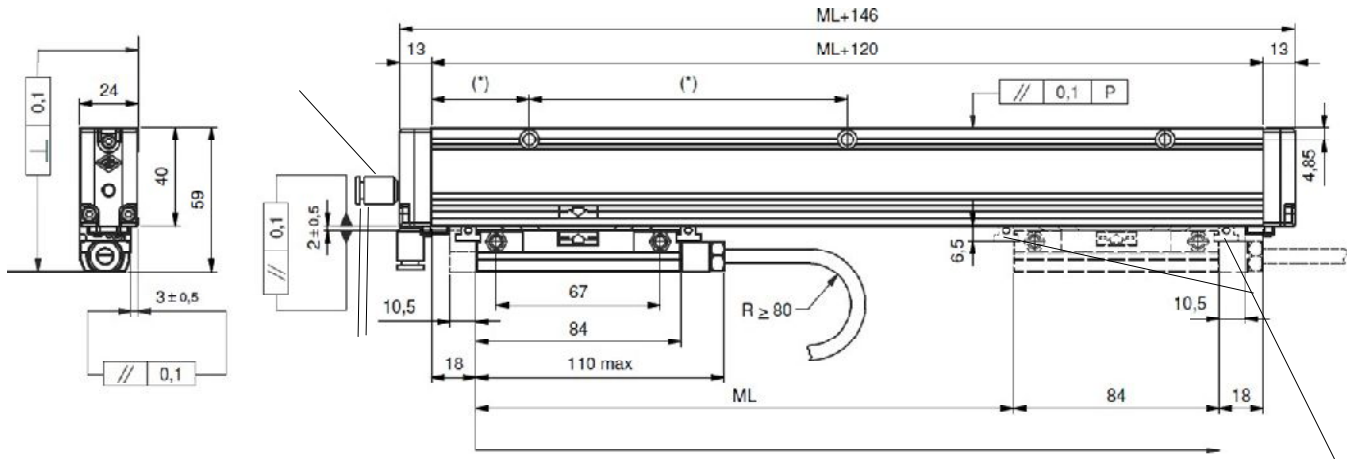

P =
ML =

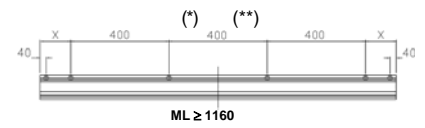
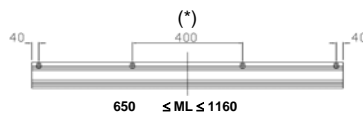
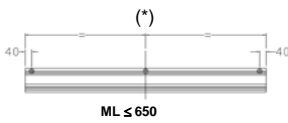

(**)

40

X > 175

GVS 608	F1A	03240	V	F1	M04 / F1	CU1	PR
----------------	------------	--------------	----------	-----------	-----------------	------------	-----------

F1 = 1
F01 = 0.1
A =

03240 = ML MAX

F1 = FANUC αi

Mnn =
M04 = 4
50 = 50
F1 = 7 -

CU1 =
FANUC αi

No cod. =
SPnn =
PR = nn



GVS 608 F1A 03240 V F1 M04/F1 CU1 PR